

FINAL SUBDIVISION PLAT FOREST VIEW ESTATES

PART OF THE WEST HALF OF THE EAST HALF OF SECTION 5, TOWNSHIP 37 NORTH,
RANGE 10 EAST OF THE THIRD PRINCIPAL MERIDIAN, IN WILL COUNTY, ILLINOIS.

THIS PLAT HAS BEEN SUBMITTED FOR
RECORDING BY AND RETURN TO:
NAPERVILLE CITY CLERK
P.O. BOX 3020
400 S. EAGLE STREET
NAPERVILLE, IL
60566.7020

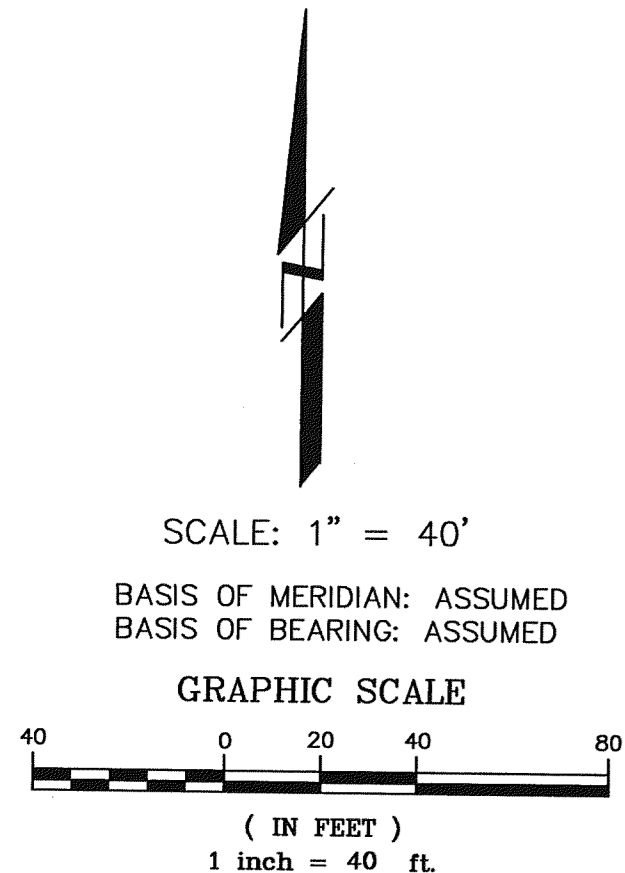

AREA SUMMARY		
LOT NO.	S.F.	ACRES
LOT 1	15,878.77	0.3645
LOT 2	13,243.78	0.3040
LOT 3	13,379.64	0.3072
LOT 4	17,320.17	0.3976
LOT 5	17,979.62	0.4128
LOT 6	15,411.21	0.3538
LOT 7	14,096.05	0.3236
LOT 8	20,387.57	0.4680
LOT 9	15,405.21	0.3537
LOT 10	12,781.52	0.2934
LOT 11	16,759.68	0.3847
LOT 12 (STORM WATER MANAGEMENT)	36,705.82	0.8426
INTERIOR R.O.W. HEREBY DEDICATED (PINE CONE COURT)	43,569.05	1.0002
R.O.W. HEREBY DEDICATED (ROYCE ROAD)	17,311.82	0.3974
TOTAL AREA IN SUBDIVISION	270,229.91	6.2036

ALL PARKWAY TREE REQUIREMENTS SHALL BE MET PURSUANT TO THE CITY OF NAPERVILLE ORDINANCE AS AMENDED.

NOTES:

1. IRON PIPES ARE AT ALL LOT CORNERS.
2. ALL EASEMENTS ARE HEREBY GRANTED UNLESS OTHERWISE NOTED.
3. ALL EASEMENTS DEPICTED ON THE PLAT ARE FOR PUBLIC UTILITIES AND DRAINAGE PURPOSES UNLESS OTHERWISE NOTED. REFER TO THE PUBLIC UTILITIES AND DRAINAGE EASEMENT PROVISIONS STATEMENT ON SHEET 2 OF 2 FOR SPECIFIC TERMS AND CONDITIONS.
4. ALL MEASUREMENTS AND DISTANCES ARE SHOWN IN FEET AND DECIMAL PARTS THEREOF.
5. DIMENSIONS SHOWN ALONG CURVED LINES ARE ARC DIMENSIONS.
6. THE ISLAND IN THE PINE CONE COURT CUL-DE-SAC SHALL BE MAINTAINED INITIALLY BY THE DEVELOPER AND SUBSEQUENTLY BY THE HOMEOWNER'S ASSOCIATION.

LEGEND

- SUBDIVISION BOUNDARY LINE
- - - BUILDING LINE
- PROPERTY LINE
- - - EASEMENT LINE
- CONCRETE MONUMENT SET
- (MEAS.) MEASURED DATA
- (REC.) RECORD DATA

ABBREVIATION TABLE

- N = NORTH
- S = SOUTH
- E = EAST
- W = WEST
- R = RADIUS
- L = LENGTH
- CB = CHORD BEARING
- CH = CHORD
- P.O.C. = POINT OF COMMENCEMENT
- P.O.B. = POINT OF BEGINNING

DEVELOPER:
FOREST JOINT VENTURE, LLC.
NAPERVILLE, IL 60564
PH: 630-820-0880
FAX: 630-820-1021



PUBLIC UTILITIES AND DRAINAGE EASEMENT PROVISIONS

EASEMENTS ARE HEREBY RESERVED FOR AND GRANTED TO THE CITY OF NAPERVILLE, ILLINOIS AND TO THOSE PUBLIC UTILITY COMPANIES OPERATING UNDER FRANCHISE FROM THE CITY OF NAPERVILLE, INCLUDING BUT NOT LIMITED TO, ILLINOIS BELL TELEPHONE COMPANY, DBA SBC ILLINOIS, NICOR GAS COMPANY AND THEIR SUCCESSORS AND ASSIGNS, OVER ALL OF THE AREA MARKED "PUBLIC UTILITIES AND DRAINAGE EASEMENTS" OR (P.U. & D.E.) ON THE PLAT FOR THE PERPETUAL RIGHT, PRIVILEGE AND AUTHORITY TO CONSTRUCT, RECONSTRUCT, REPAIR, INSPECT, MAINTAIN AND OPERATE VARIOUS UTILITY TRANSMISSION AND DISTRIBUTION SYSTEMS, COMMUNITY ANTENNA TELEVISION SYSTEMS AND INCLUDING STORM AND/OR SANITARY SEWERS, TOGETHER WITH ANY AND ALL NECESSARY MANHOLES, CATCH BASINS, CONNECTIONS, APPLIANCES AND OTHER STRUCTURES AND APPURTENANCES AS MAY BE DEEMED NECESSARY BY SAID CITY, OVER, UPON, ALONG, UNDER AND THROUGH SAID INDICATED EASEMENTS, TOGETHER WITH RIGHT OF ACCESS ACROSS THE PROPERTY FOR NECESSARY MEN AND EQUIPMENT TO DO ANY OF THE ABOVE WORK.

THE RIGHT IS ALSO GRANTED TO TRIM OR REMOVE ANY TREES, SHRUBS OR OTHER PLANTS ON THE EASEMENTS THAT INTERFERE WITH THE OPERATION OF THE SEWERS OR OTHER UTILITIES. NO PERMANENT BUILDINGS SHALL BE PLACED ON SAID EASEMENTS BUT SAME MAY BE USED FOR GARDENS, SHRUBS, LANDSCAPING AND OTHER PURPOSES THAT DO NOT THEM OR LATER INTERFERE WITH THE AFORESAID USES OR RIGHTS. WHERE AN EASEMENT IS USED BOTH FOR SEWERS AND OTHER UTILITIES, THE OTHER UTILITY INSTALLATION SHALL BE SUBJECT TO THE ORDINANCES OF THE CITY OF NAPERVILLE.

EASEMENTS ARE HEREBY RESERVED FOR AND GRANTED TO THE CITY OF NAPERVILLE AND OTHER GOVERNMENTAL AUTHORITIES HAVING JURISDICTION OF THE LAND SUBDIVIDED HEREBY, OVER THE ENTIRE EASEMENT AREA FOR INGRESS, EGRESS AND THE PERFORMANCE OF MUNICIPAL AND OTHER GOVERNMENTAL SERVICES, INCLUDING WATER, STORM AND SANITARY SEWER SERVICE AND MAINTENANCE.

REVISED: 8-26-2004 NONE THIS SHEET
REVISED: 7-20-2004 PER C.O.N. REVIEW
PREPARED: JUNE 4, 2004

CITY OF NAPERVILLE PROJECT #02-10000104
INTECH CONSULTANTS, INC.
ENGINEERS / SURVEYORS
5413 WALNUT AVE. DOWNERS GROVE, IL (630) 964-5656
SHEET No. 1 of 2 JOB No.: 2004-003

C:\land\Projects\2004\2004-003\dwg\2004-003SUBP.dwg, SUB PLAT-1, 7/20/2004 8:14:03 AM, BY: GGE